

2

1

B

B

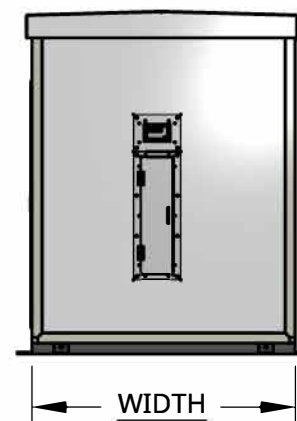
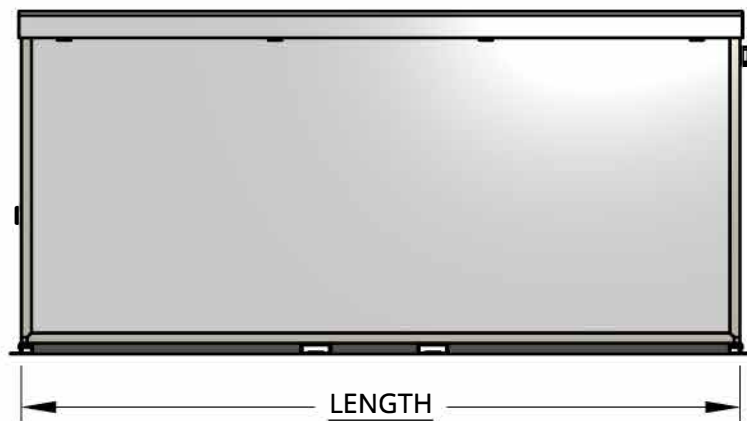

HEIGHT

LENGTH

WIDTH

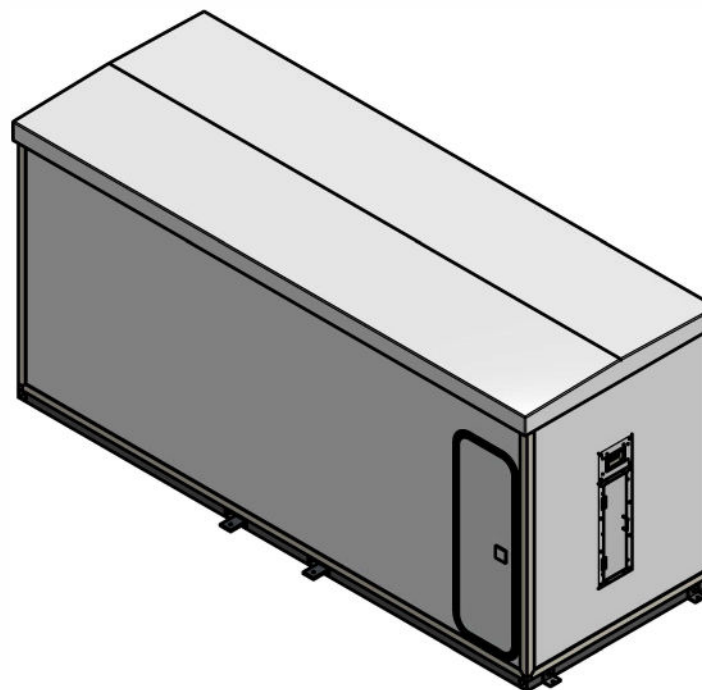

A

A

**TANK OPTIONS**

TANK SIZE	LENGTH (IN)	WIDTH (IN)	HEIGHT (IN)
2000G	197	72	94
3400G	192	93	105
5000G	227	100	116
6000G	231	110	123

2



PROJECT				COMMERCIAL PLATINUM - WIDE END DISPENSE	
DWG. NO.			DRAWN		REV
SD-PLT-COM-S3			NP		001
SCALE			SHEET		REV DATE
1:52.5			A		08/11/2023
			SHEET		1 OF 2

1

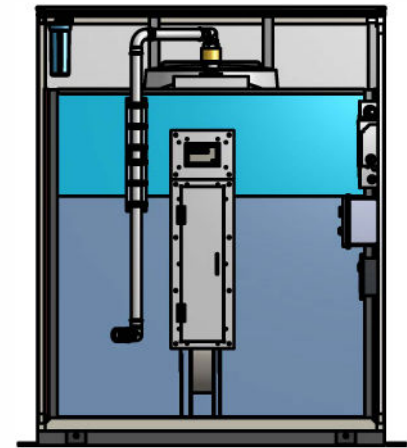
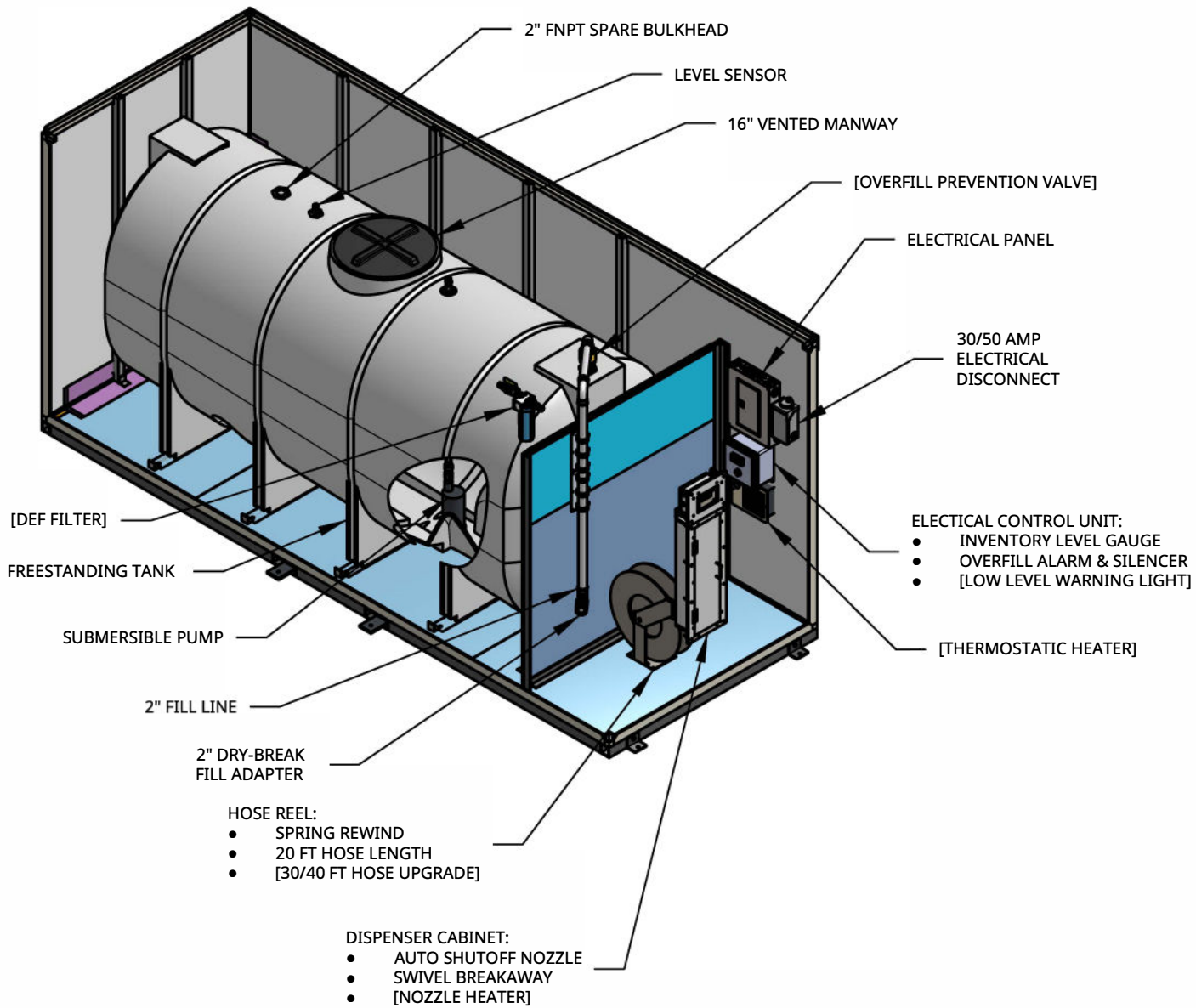

PROJECT				COMMERCIAL PLATINUM - WIDE END DISPENSE	
DWG.				PLUMBING AND ELECTRICAL	
DWG. NO.				DRAWN	REV DATE
SD-PLT-COM-S3		NP	08/11/2023		REV 001
SCALE	SIZE	SHEET			
1:40	A	2 OF 2			